

2030 TECHNICAL DATA

2000 Series panels, Hinged in Pairs

KWIK-WALL... One Source for Wall Systems.

KWIK-WALL's 2000 Series - Operable wall systems answer the challenge for space division needs posed by multi-purpose room layouts. Years of continuing research and development have produced many outstanding features!

KWIK-WALL's Model 2030 is the most popular panel configuration in the industry. Panels are hinged together in groups of two (2) to allow for quick and easy movement of multiple panels from the storage location to the installed position. The track system is a continuous straight run which also simplifies the structural header requirements that are necessary to support the wall system. A full range of panel finishes, options and accessories are available to customize the wall to best suit your requirements.

SOUND CONTROL...

KWIK-WALL's 2000 Series Steel Panel is a complete line of acoustically rated wall systems that are designed and manufactured to meet the most demanding sound control requirements. Sound Transmission Class (STC) ratings from 42 STC to 51 STC have been tested and certified in an independent acoustical laboratory in accordance with ASTM E 90 and ASTM E 413 test procedures. The STC ratings represent a single number expression of the effectiveness of an operable wall in preventing the passage of transmitted sound in the range* of 125 Hz to 4,000 Hz. For assistance with designing room division applications using Operable, Glass or Accordion wall systems, please contact your local KWIK-WALL distributor.

*The average human ear has an audibility range from 125 Hz to 4,000 Hz. Levels in excess of 65 dB to 70 dB are generally too loud for ordinary speech communication. When the sound pressure exceeds 120 dB, it normally passes the threshold of pain.

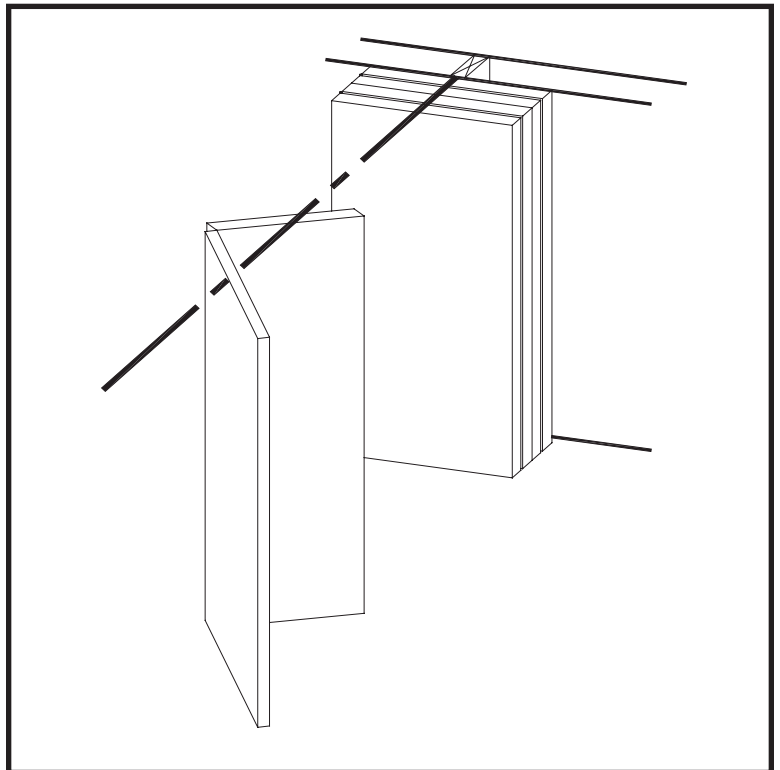



1.01 WORK INCLUDED

- A. Operable Wall System shall be furnished, installed and serviced by KWIK-WALL's authorized distributor, in compliance with the architectural drawings and specifications contained herein.

1.02 RELATED WORK

- A. Structural Support: Structural support system required for suspending the operable wall shall be designed, installed and pre-punched by others, in accordance with ASTM E 557 and KWIK-WALL's shop drawings.
- B. Insulation: Sound insulation and baffles for the plenum area above the track system, under the permanent floor, inside air ducts passing over or around the operable wall, and in permanent walls adjoining the operable wall system shall be by others, in accordance with ASTM E 557.
- C. Opening Preparation: Proper and complete preparation of the operable wall system opening shall be by others in accordance with ASTM E 557, and shall include floor leveling; plumbness of adjoining permanent walls; substrate and or ceiling tile enclosures for the track system; and the painting and finishing of trim and other materials adjoining the head and jamb areas of the operable wall. Any permanent wall(s) receiving an adjustable or fixed wall jamb will require internal structural blocking in order to secure the jamb to the permanent wall. Refer to a copy of the shop drawings for additional details.

1.03 SYSTEM DESCRIPTION

- A. The operable wall system shall consist of Hinged Pair Panels that are top supported by one (1) carrier. Featuring panels hinged together in evenly matched pairs (groups of two (2)), unless otherwise specified.
- B. The operable wall system shall consist of acoustically rated panels tested in accordance with ASTM E 90 and ASTM E 413 test procedures, and shall have achieved a STC rating as specified herein (see "Acoustical Performance" article listed under Part 2 - Products).

1.04 QUALITY ASSURANCE

- A. The operable wall shall have been tested in an independent acoustical testing laboratory in accordance with ASTM E 90 and ASTM E 413 test procedures.
- B. The operable wall panel construction and finish materials shall consist of Class A rated materials (except as noted, under "Finishes" Part 2 – Products) in accordance with ASTM E 84.
- C. The operable wall shall be installed by KWIK-WALL's authorized distributor in accordance with ASTM E 557.

1.05 REFERENCES

- A. ASTM E 90: Laboratory Measurement of Airborne-Sound Transmission Loss of Building Partitions.
- B. ASTM E 413: Determination of Sound Transmission Class (STC).
- C. ASTM E 557: Architectural Application and Installation of Operable Partitions.
- D. ASTM E 84: Surface Burning Characteristics of Building Materials.
- E. ASTM A 653: Specification for General Requirements for Steel Sheet, Alloy-Coated (Galvanneal) by the Hot Dip Process.
- F. ASTM C 423: Standard Test Method for Sound Absorption and Sound Absorption Coefficients by the Reverberation Room Method.

- G. CCC-W-408A: Federal Specification which applies to Vinyl Coated Wall Coverings.
- H. CFFA-W-101-D: Chemical Fabrics and Film Association Quality Standard for Vinyl Coated Fabric Wall Coverings

1.06 SUBMITTALS

- A. KWIK-WALL shall provide written technical information and related detail drawings, which demonstrate that the products comply with contract documents for each type of operable partition specified.
- B. KWIK-WALL shall provide detailed engineering drawings featuring track plan, panel elevation, horizontal and vertical details and beam punching template as required.
- C. KWIK-WALL shall provide written test report of the independent acoustical testing laboratory certifying the attainment of the specified STC rating, upon request.
- D. KWIK-WALL shall provide written instructions specifying the proper operation and maintenance of the operable wall system.
- E. KWIK-WALL shall provide a color selector demonstrating the manufacturer's selections of the specified finish material. Samples shall consist of actual swatches of the specified finish material.

1.07 DELIVERY, STORAGE AND HANDLING

- A. Panels shall be individually wrapped in a protective plastic covering to keep panels clean during delivery, storage and handling.
- B. Panels shall be stored on edge and above the floor on cushioned blocking in a dry and ventilated area, protected from humidity and temperature extremes.

1.08 SEQUENCING / SCHEDULING

- A. Beam Punching: KWIK-WALL shall provide beam punching template drawing detailing the anchor locations for the suspended track system (as required for Drop Rod Mounting), as required for the fabrication and installation of structural overhead support by others.
- B. Track Installation: Scheduling of operable wall track installation shall occur after structural overhead support has been properly and completely fabricated and installed by others.
- C. Panel Installation: Operable wall panel installation shall occur after fixed wall substrate construction is properly and completely installed by others, as required to protect panels from ongoing adjacent construction.

1.09 WARRANTY

- A. KWIK-WALL shall warrant each operable wall panel and its component parts to be free from defects in material and workmanship for a period of five (5) years from the date of delivery to the original purchaser, when installed by an authorized KWIK-WALL distributor. KWIK-WALL also warrants the fixed top seals, track, carriers, and its component parts to be free from defects in material and workmanship for a period of ten (10) years. (see actual warranty on Page 12 for details and limitations).



2.01 ACCEPTABLE MANUFACTURER

A. Operable walls shall be Series 2000, Model 2030 Hinged Pairs as manufactured by KWIK-WALL Company.

2.02 PANEL CONSTRUCTION

- A. Panel Dimensions: Standard panel dimension shall be a nominal 3" [76] thick.
- B. Panel Frame: Vertical steel frame members shall be minimum 18-gauge galvaneal steel, horizontal top cross member shall be minimum 12 - gauge galvaneal steel, which meets or exceeds ASTM A 653 requirements. Frame shall be all-welded construction with steel corner supports and cross-bracing reinforcements. Panel frame shall be Class A rated fire retardant, non-combustible and non-corrosive in accordance with ASTM E 84
- C. Panel Skins: Panel skins shall be Class A rated (except Wood Veneer and High Pressure Laminate) in accordance with ASTM E 84. Panel skin material shall consist of (select):
 - 1. Standard Acoustical Substrate: consisting of structural acoustical substrate pressure laminated to both sides of the steel frame to form a rigid, unitized and structural panel.
 - 2. Optional Steel Skins: consisting of minimum 22-gauge tension-leveled galvaneal steel, pressure laminated to a structural acoustical backer and too the steel frame to form a rigid, unitized and structural panel.
 - 3. Optional Wood Veneer: consisting of particle board core covered with wood veneer and pressure laminated to both sides of the steel frame to form a rigid, unitized and structural panel.
 - 4. Optional High Pressure Laminate: consisting of gypsum board core covered with general purpose plastic laminate and Phenolic backer sheet, which is pressure laminated to both sides of the steel frame to form a rigid, unitized and structural panel.
- D. Panel Hinges: Panel hinges shall be architectural grade, full leaf butt hinges. Hinges shall be attached to the steel frame of the panel and reinforced with a steel backer plate.
- E. Panel Weight: Maximum panel weight shall be 6.5 - 11.0 lb./ft.² (32 - 54 kg/m²) depending on STC rating, size and options selected.

2.03 OPERATION

A. Operation shall be Hinged Pairs, consisting of panels hinged together in groups of two (2), unless otherwise specified. Panels shall be top-supported by one (1) carrier in each panel.

2.04 STACK ARRANGEMENTS

- A. Stack Type: Panel storage configuration shall be Center Stack, consisting of panels stacked on center to the wall's installed position.
- B. Stack Quantity: Panels shall be stored at (select):
 - 1. Standard One End: on one end of the wall run.
 - 2. Optional Both Ends: on both ends of the wall run.

2.05 FINISHES

A. Finish Material Type: Panel finish material shall be Class A (except wood veneer and high pressure laminate) rated in accordance with ASTM E 84, consisting of (select):

- 1. Vinyl: consisting of Type II, reinforced vinyl weighing 21 oz./ lin. yd. (651 g/lin. m). Upgrade Vinyl shall meet or exceed CCC-W- 408A and CFFA-W-101-D quality standards.
- 2. Optional Upgrade Fabric: consisting of fade and tear resistant fabric that resists water-based stains weighing 13 oz./lin. yd. (403 g/lin. m).
- 3. Optional Basics Carpet: consisting of acoustically absorbent, non-woven needle punch fibers fused to prevent fraying and unraveling of material weighing 28.5 oz./lin. yd. (884 g/lin. m). Basics Carpet shall achieve a minimum NRC rating of .20 (applied over gypsum substrate) in accordance with ASTM C 423.
- 4. Optional Upgrade Carpet: consisting of acoustically absorbent, non-woven needle punch fibers fused to prevent fraying and unraveling of material weighing 23 oz./lin. yd. (713 g/lin. m). Upgrade Carpet shall achieve a minimum NRC rating of .25 (applied over gypsum substrate) in accordance with ASTM C 423.
- 5. Optional Wood Veneer: consisting of unfinished flat cut wood veneer laminated to 1/2" [12.7] thick particle board core. Veneer shall be book / running matched within a panel. (Notes: Optional Class "A" rated particle board is available. Acoustical substrate STC ratings apply for Wood Veneer panel construction.)
- 6. Optional High Pressure Laminate: consisting of gypsum board core covered with general purpose plastic laminate and Phenolic backer sheet, which is pressure laminated to both sides of the steel frame to form a rigid, unitized and structural panel. (Note: Acoustical substrate STC ratings apply for High Pressure Laminate panel construction.)
- 7. Optional Unfinished: consisting of panels with exposed acoustical substrate or steel skins for field applied wallcovering or painting

MODEL 2030 PRODUCT GUIDE <i>Optional Steel Skin Construction</i>				
STC Rating	Panel Thickness (nominal)	Max. Panel Weight lb./ft. ²	Maximum Panel Height	Maximum Wall Width
49	3" [76]	8.0 [39kg/m ²]	16'-2" (4.93 m)	Unlimited
51	3" [76]	11.0 [53.7 kg/m ²]	16'-2" (4.93 m)	Unlimited

*Note: Optional Wood Veneer or High Pressure Laminate only available as Acoustical Substrate Construction

MODEL 2030 PRODUCT GUIDE <i>Standard Acoustical Substrate Construction</i>				
STC Rating	Panel Thickness (nominal)	Max. Panel Weight lb./ft. ²	Maximum Panel Height	Maximum Wall Width
42	3" [76]	6.5 [32 kg/m ²]	14'-2" (4.32 m)	Unlimited
45	3" [76]	7.5 [36.6 kg/m ²]	14'-2" (4.32 m)	Unlimited
49	3" [76]	9.0 [44 kg/m ²]	14'-2" (4.32 m)	Unlimited
50	3" [76]	9.0 [44 kg/m ²]	14'-2" (4.32 m)	Unlimited

* Estimated panel weights are for intermediate panels. Weight may vary due to substrate, size, or function of panel. Add 105 lbs [47kg] for pass door. Add 6 lbs [3kg] per lin ft height for expanders. Add 3.5 to 8 lbs [1.6 to 3.6kg] per lin ft for track.

**Standard features can be modified, contact your Kwik-Wall distributor for the features you want.

*** Horizontal Splice: Heights over 14'2" [4.31] with Acoustical Substrate require a structural splice.

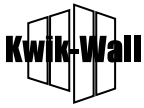

- B. Finish Material Supplier: Finish material shall be (select):
1. Standard Factory Supplied: from manufacturer's standard selection of finish materials, as specified.
 2. Optional Customer Supplied: from customer's selection of finish material, by others, and as approved by KWIK-WALL Company
- C. Finish Material Application: Finish material shall be (select):
1. Standard Factory Applied: by operable wall manufacturer. Customer supplied finish material samples must be submitted to manufacturer for testing and approval prior to acceptance and application.

3. Optional Automatic Bottom Seals: consisting of self activated seals providing 2" [50.8] of nominal travel.
- D. Horizontal and Vertical Panel Trim: All exposed panel trim and hinges shall be of one (1) similar color (select):
1. Dark Bronze
 2. Grey

2.07 CLOSURE SYSTEMS

- A. Initial Closure System: The lead panel (the first panel exiting the stack) shall form a seal vertically against a rigid wall surface, as accomplished by a (select):
1. Standard Bulb Seal: consisting of continuous-contact, flexible vinyl bulb seals installed along the vertical edge of the lead panel for positive compression against a rigid wall surface.
 2. Optional Fixed Starter Jamb: consisting of an aluminum extrusion, which is permanently mounted to a structural wall surface. The Fixed Starter Jamb shall incorporate a tongue-and-groove-type vertical astragal for positive interlocking with the lead panel.
 3. Optional Adjustable Starter Jamb: consisting of an aluminum extrusion which is permanently mounted to a structural wall surface and is field-adjustable to compensate for out-of-plumb conditions of the fixed wall. The Adjustable Starter Jamb shall incorporate a tongue-and-groove-type vertical astragal for positive interlocking with the lead panel.

2.06 PERIMETER TRIM AND SEALS

- A. Vertical Trim and Seals: Panels shall have vertical astragals containing flexible vinyl seals and incorporate reversible tongue-and-groove-type configurations for positive interlocking with adjacent panels. Vertical astragal type shall be (select):
1. Standard Trimless Astragal: consisting of an aluminum extrusion with tongue-and-groove-type vertical astragals. Vertical trim shall not be permitted on the panel faces, resulting in a minimal groove appearance between adjacent panels.
 2. Optional Cap-type Astragal: consisting of an aluminum extrusion with tongue-and groove-type vertical astragals for encapsulating and protecting the finish material and substrate along the vertical edge of the panel.
- B. Horizontal Top Trim and Seals: Top seals shall consist of flexible vinyl sweep seals installed on both sides of the panel. The seals shall consist of a compressed bulb between two (2) fingers of vinyl. Top seal type shall be (select):
1. Standard Fixed Top Seals: consisting of continuous-contact flexible vinyl, sealing against the bottom flange of the over head track.
 2. Optional Operable Top Seals: consisting of an edge-activated seal using a removable wrench as supplied by manufacturer. Top seals shall provide a maximum 1/2" [13] of travel.
- C. Horizontal Bottom Trim and Seals: Bottom seals shall consist of multiple fingers of flexible vinyl for positive contact and sealing with various floor surfaces. Bottom seal type shall be (select):
1. Standard Operable Bottom Seals: consisting of an edge-activated seal using a removable wrench as supplied by manufacturer. Bottom seals shall provide 2" [50.8] of nominal travel.
 2. Optional Adjustable Bottom Seals: consisting of field adjustable, continuous-contact vinyl sweep seals with 2" [50.8] nominal height with 3/4" [19] of nominal adjustment.

- B. Final Closure System: The final closure panel (the last panel exiting the stack) shall form a seal vertically against a rigid wall surface. The type of final closure panel shall be (select):
1. Standard Expander Panel Closure: consisting of an expander mechanism with a nominal 5" [127] of travel, activated from the face of the panel using a removable wrench as supplied by manufacturer. The Expander Panel shall be equipped with an adjustable bottom seal (standard) or (optional) operable bottom seal, and a flush pull handle.
 2. Optional Hinged Panel(s) Closure: consisting of a panel hinged permanently and directly to a structural wall surface. The Hinged Panel(s) shall be equipped with an adjustable bottom seal, a lap-type extrusion for sealing against its adjacent panel (standard) or (optional) expander mechanism with a nominal 5" [127] of travel, activated from the face of the panel using a removable wrench, and a flush pull handle on each side of the panel.
 3. Optional Communicating Panel Closure: consisting of a full-sized panel hinged permanently and directly to a structural wall surface. The Communicating Panel shall function as a full height pass door (maximum panel size: 3'-0" (.91 m) wide x 10'-2" (3.10 m) high), with an adjustable bottom seal, a lap-type extrusion for sealing against its adjacent panel, and a flush pull handle on each side of the panel.
 4. Optional Lap Closure: consisting of a pair of panels equipped with bulb seals for sealing against a rigid wall surface along one (1) vertical edge, and a lap-type extrusion that overlaps with the adjacent panel on the opposite edge. The Lap Closure panels shall be equipped with adjustable bottom seals, and a flush pull handle.
 6. Optional Single Panel Expander Closure: consisting of an expander mechanism with a nominal 5" [127] of travel, activated from the face of the panel using a removable wrench. The Single Panel Expander shall be capable of rotating 360° and shall be equipped with an adjustable bottom seal (standard) or (optional) operable bottom seal, and a flush pull handle.

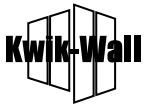

7. Optional Pocket Door(s): (see "2000 Series Pocket Door" brochure for complete details and specifications).

Note: Optional Automatic Bottom Seal is not available in conjunction with Final Closure panel(s).

2.08 ACOUSTICAL PERFORMANCE

A. Certification: The operable wall shall have been tested in an independent acoustical testing laboratory in accordance with ASTM E 90 and ASTM E 413 test procedures.

B. STC Rating: The operable wall acoustical performance rating shall be based on (select):

1. Standard Acoustical Substrate: with a standard rating of 49 STC, or optional ratings of 42 STC, 45 STC or 50 STC.
2. Optional Steel Skins: with optional ratings of 49 STC or 51 STC.

(Note: Not available with optional Wood Veneer or High Pressure Laminate.)

2.09 PANEL ACCESSORIES

A. Accessories including Pass Doors; Single or Double, Concealed Door Closures, Room Viewers, Exit Signs, Dry Marker Writing Surfaces, Recessed Eraser Trays, Vision Lites, Tack Surfaces and Pocket Doors shall be compatible with other accessories and options, furnished and installed by KWIK-WALL's authorized distributor as noted on submitted shop drawings.

2.10 TRACK SYSTEMS

A. Track Type: The operable wall track system shall be (select):

1. Standard Hinged Pairs Aluminum Track: extruded from structural aluminum alloy, which prohibits deterioration caused by rust or corrosion. The aluminum track shall have a durable anodized clear satin finish, which resists color fading and flaking. The track shall utilize grooves and interlocking steel pins for positive alignment of adjacent track sections. The track joints shall be reinforced overhead by a heavy-duty steel bracket made of hot-rolled, 3/8" [10] thick plate steel. Aluminum track shall include an integral nut slot to accept a hardened steel square nut to facilitate attachment of each steel all-rod and splice brackets to the overhead structural support.
2. Optional Hinged Pairs Steel Track: consisting of roll formed, low carbon steel, .215" [5] thick. The steel track shall have a durable powder-coated, off-white finish, which resists color

fading and flaking. The steel track shall be reinforced overhead by heavy duty steel brackets made of hot-rolled, 3/8" [10] thick plate steel, as required for attaching threaded all-rod to the overhead structural support and for aligning track sections at each splice joint.

B. Track Size: The track size shall be (selected from Track and Carrier Selection Chart - refer to chart below):

1. Type 425 Hinged Pairs Aluminum Track: certified to be capable of supporting up to 525 lb. (238 kg) of total live load weight per panel.
2. Type 850 Hinged Pairs Aluminum Track: certified to be capable of supporting up to 850 lb. (386 kg) of total live load weight per panel.
3. Type 850 Hinged Pairs Steel Track: certified to be capable of supporting up to 850 lb. (386 kg) of total live load weight per panel.

2.11 CARRIER SYSTEMS

A. Carrier Type: Each Hinged Pair panel shall be top supported by one (1) carrier utilizing a 5/8" [16] diameter pendant bolt. The carrier type shall be (select):

1. Type 425 Polymer Tire Carrier: consisting of four (4) permanently-lubricated, precision ball bearing steel wheels with high strength polymer tires, as required for smooth and quiet operation.
2. Type 850 Polymer Tire Carrier: consisting of eight (8) permanently-lubricated, precision ball bearing steel wheels with high strength polymer tires, as required for smooth and quiet operation.
3. Type 850 Steel Wheel Carrier: consisting of four (4) permanently-lubricated, precision ground ball bearing polished steel wheels, as required for ease of panel movement.

B. Carrier Size: The carrier size shall be (select from Track and Carrier Selection Chart - refer to chart below):

1. Type 425 Hinged Pairs Polymer Tire Carrier: certified to be capable of supporting up to 525 lb. (238 kg) of total live load weight per panel.
2. Type 850 Hinged Pairs Polymer Tire Carrier: certified to be capable of supporting up to 850 lb. (386 kg) of total live load weight per panel.

MODEL 2030 - TRACK AND CARRIER SELECTION CHART											
Panel Skin Type	Maximum Panel Weight lb./ft ²	STC Rating	Panel Fabrication Height*								
			Up to 8' - 2" (2.49 m)	Up to 9' - 2" (2.79 m)	Up to 10' - 2" (3.10 m)	Up to 11' - 2" (3.40 m)	Up to 12' - 2" (3.71 m)	Up to 13' - 2" (4.01 m)	Up to 14' - 2" (4.32 m)	Up to 15' - 2" (4.62 m)	Up to 16' - 2" (4.93 m)
Acoustical Substrate	6.5 (32 kg/m ²)	42									Not Available
Acoustical Substrate	8.5 (41 kg/m ²)	45									
Acoustical Substrate	9.0 [44 kg/m ²]	49	425 TRACK & CARRIERS								
Acoustical Substrate	9.0 [44 kg/m ²]	50									
Steel Skin	8.0 [39kg/m ²]	49									
Steel Skin	11.0 [53.7 kg/m ²]	51									

*Based on 4' - 0" (1.22 m) Intermediate panel widths.

Depending on panel options selected, KWIK-WALL may require 850 Track & Carriers.

- 3. Type 850 Hinged Pairs Steel Wheel Carrier: certified to be capable of supporting up to 850 lb. (386 kg) of total live load weight per panel.

2.12 SUSPENSION SYSTEMS

- A. Mounting Systems: The track shall be supported by (select):
 - 1. Standard Drop Rod Mount: consisting of adjustable rods of grade 2, 3/8" [10] diameter threaded steel all rod provided with 3/8" [10] serrated steel nuts.
 - 2. Optional Direct Mount: consisting of 3/8" [10] x 3" [76] lag screws for attachment to an overhead structural (wood) support. (Direct mount track installations should not exceed 425 lb. (193 kg) of panel weight).
 - 3. Optional Drop Rod Bracket Mount: consisting of 3/8" [10] thick steel brackets mounted to top of track and supported with adjustable rods of grade 2, 3/8" [10] diameter threaded steel all-rod provided with 3/8" [10] serrated steel nuts.

3.01 INSPECTION

- A. Proper and complete preparation of the operable wall system opening shall be by others in accordance with the architectural drawings, KWIK-WALL's shop drawings and ASTM E 557. Any deviation of the actual opening from these specifications shall be called to the attention of the architect prior to the installation of the operable wall.
- B. Deficiencies in the operable wall opening shall be corrected by others prior to installation of the operable wall.

3.02 INSTALLATION

- A. The operable wall system shall be installed by KWIK-WALL's authorized distributor.
- B. The operable wall shall be installed in accordance with KWIK-WALL's written instructions, shop drawings and ASTM E 557 installation guidelines.

3.03 ADJUSTING AND CLEANING

- A. The operable wall panels and track system shall be adjusted and cleaned in accordance with KWIK-WALL's written instructions.

3.04 PROTECTION

- A. The operable wall panels shall be stored in the stacked (retracted) position prior to acceptance by the owner's representative.

3.05 DEMONSTRATION

- A. KWIK-WALL's authorized distributor shall demonstrate proper operation and explain proper and necessary maintenance requirements of the operable wall system to the owner's representative.

OPTIONS AND ACCESSORIES

KWIK-WALL offers a full complement of accessories for customizing any operable wall system to meet the specific needs of the most demanding project.

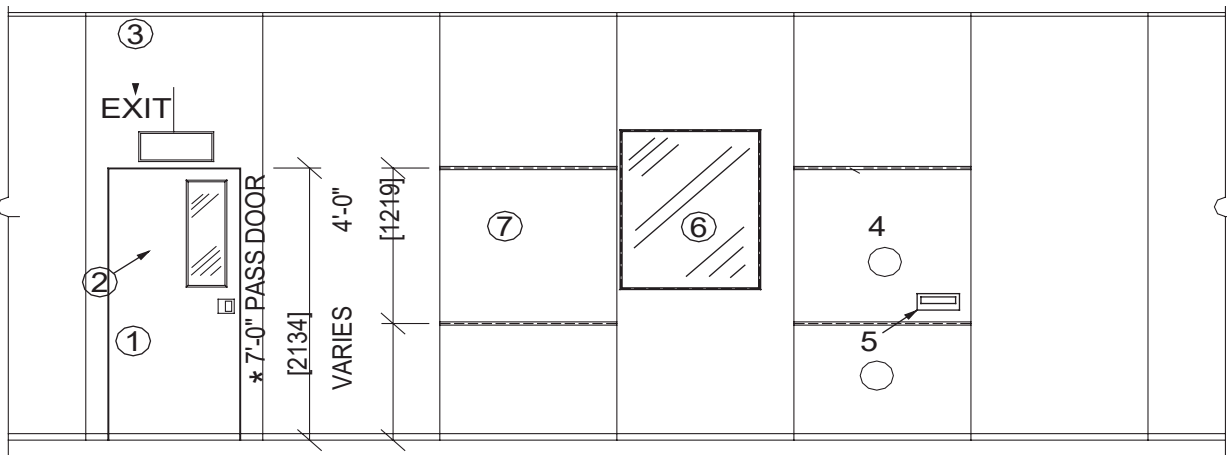

ACCESSORIES

- 1. Pass Door (Single shown, double available)
- 2. Pass Door Vision Lite
- 3. Exit Sign
- 4. Writing Surface
- 5. Recessed Eraser Tray
- 6. Panel Vision Lite
- 7. Tack Surface
- 8. Pocket Door (Not shown)

Notes:

- 1. * 7' - 8" (2.34m) minimum panel fabrication height required.
- 2. For complete specifications and details of KWIK-WALL Accessories, please visit our website at www.kwik-wall.com.

Level wood header by others.
3/8" [9.5] x 3" [76] Lag Screws
w/ Flat Washers by K.W.Co.

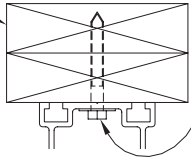

Optional Direct Mount

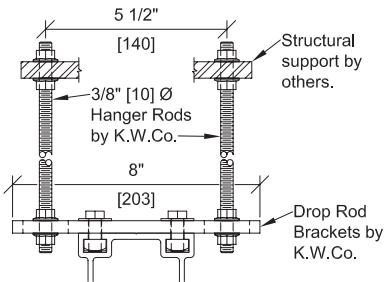

Optional Drop Rod Bracket Mount

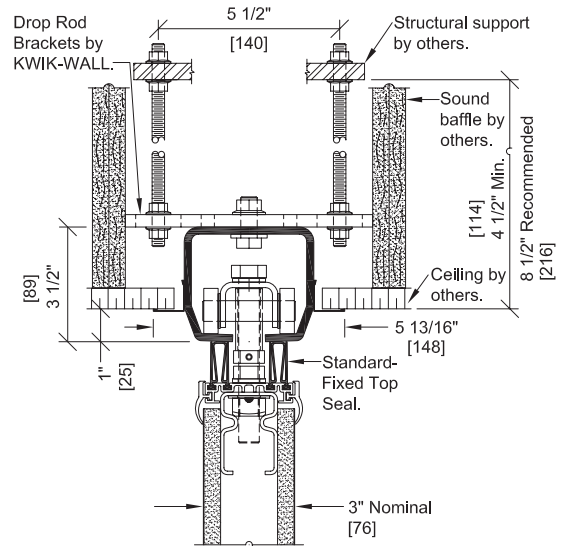

**850 Hinged Pairs
Steel Track and Carrier**

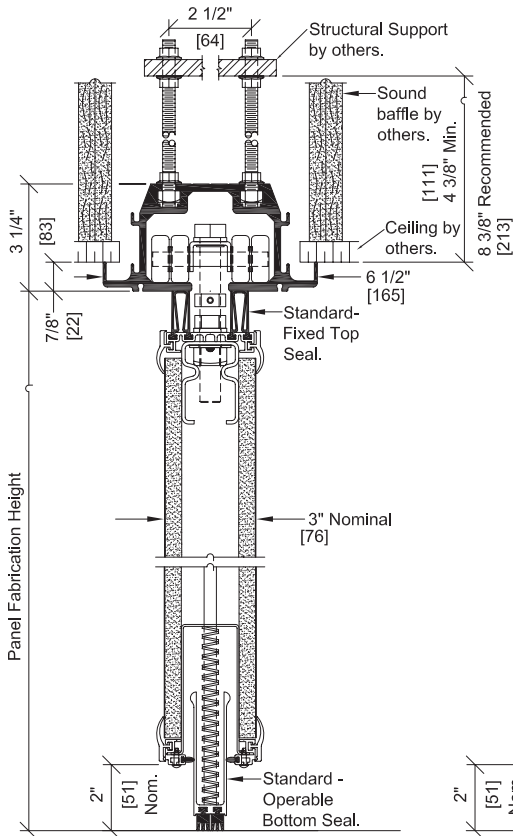

**850 Hinged Pairs
Aluminum Track and Carrier**

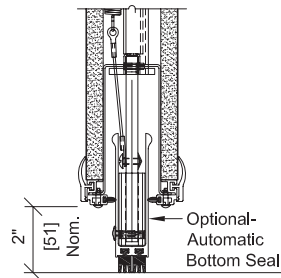

**Automatic
Bottom Seal**

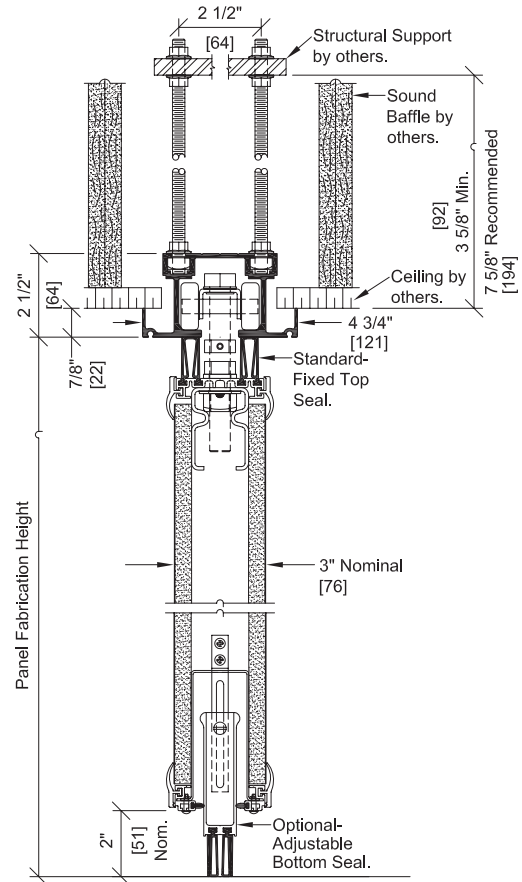

**425 Hinged Pairs
Aluminum Track and Carrier**

Notes:

1. Optional automatic bottom seal is not available with final closure panel(s).

Standard Center Stack

Panels are conveniently stored at one or both ends and stacked on-center to the wall's installed position.

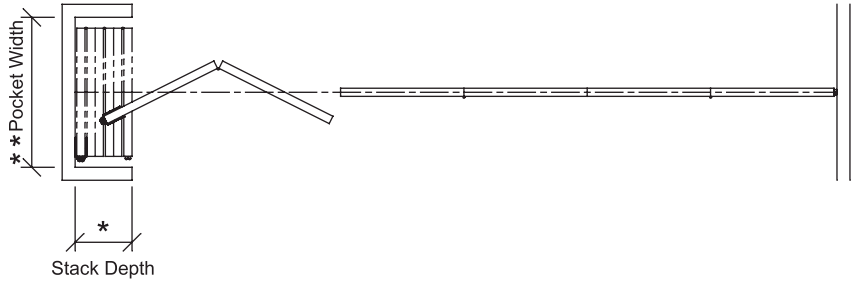

Stack Depth*

The overall depth of the stack area, as required for panel storage, is dictated by the total number of panels in the wall system. KWIK-WALL's Model 2030 - Steel Reinforced panels require an average stack depth of 3 1/2" [89] per panel. To determine the stack depth, calculate as follows:

Number of Panels x 3 1/2" [89]

*Note: Additional stack depth is required for wall systems containing the following type of panels:

- Expander Panel Closure or Pass Door Panel: 3/4" [19]
- Hinged Panel(s) Closure: 4" [102]
- Pocket Door(s): 6" [152]

**For wall systems that include Pocket Doors, please reference KWIK-WALL's "2000 Series Pocket Door" brochure for pocket layout dimensions and applications.

Pocket Width**

The width of the pocket is determined by the widest panel in the wall run. For specification purposes, assume the widest panel is 4'-0" (122 cm) maximum. Wall systems that utilize Automatic type bottom seals will require extra pocket width to allow clearance for the actuator that protrudes from the bottom of the lead panel. Pocket width may be calculated as follows:

If Adjustable or Operable Bottom Seals are specified:

Widest Panel + 7" [178]

(allows 3 1/2" [89] for hand clearance on each side)

If Automatic Bottom Seals are specified:

Widest Panel + 10" [254]

(for actuator clearance on one side)

plus

3 1/2" [89]

(for hand clearance on the other side)

FINAL CLOSURE SYSTEM

Standard Expander Panel Closure

The final closure panel is equipped with an expander closure located on the vertical edge of the panel that mechanically telescopes outward to create a positive contact seal with a rigid wall, pocket door or jamb. The expander closure is activated by inserting a wrench into an escutcheon plate located on the panel face. The expander panel is equipped with a flush pull handle and an adjustable bottom seal (standard) or (optional) operable bottom seal.

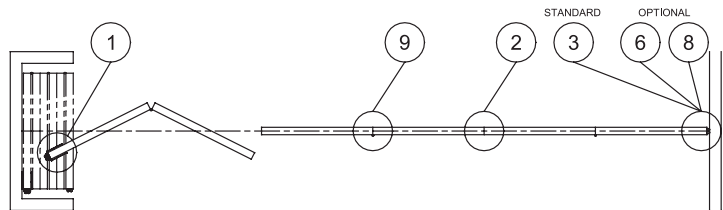

Optional Hinged Panel Closure (Single or Double)

This final closure configuration is accomplished by a (single) half panel which is hinged permanently and directly to a structural wall (as shown at right). The double version includes a second panel that is hinged to the half panel. The closure panel(s) features an adjustable bottom seal(s) and includes a flush pull handle on each side of the panel.

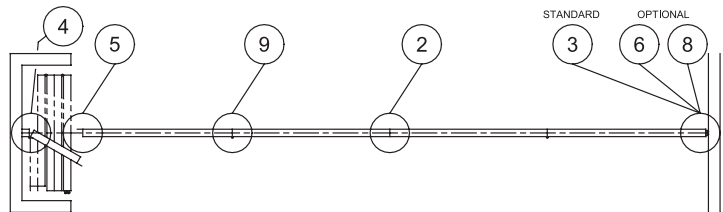

Optional Communicating Panel Closure

This final closure panel is a full-sized panel (maximum 3'-0" [914] wide x 10'-2" [3110] high) which is hinged permanently and directly to a structural wall. The Communicating panel functions as a full height pass door, incorporates an adjustable bottom seal and includes a flush pull handle on each side of the panel.

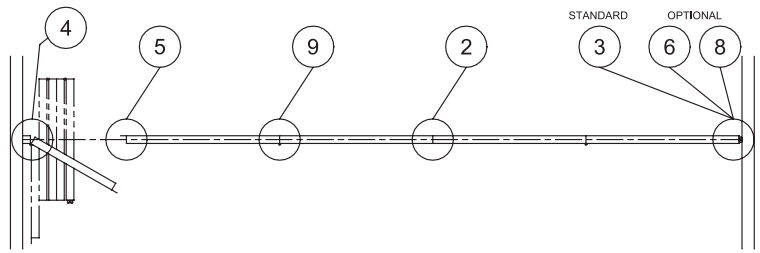

Optional Lap Panel Closure

The final closure is accomplished by two (2) panels equipped with bulb seals for sealing against a rigid wall surface on one (1) side, and a lap-type extrusion that overlaps with the adjacent panel on the opposite side. The lap closure panel is equipped with adjustable bottom seals and includes a flush pull handle.

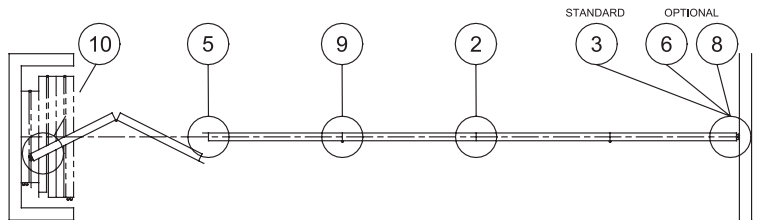

Optional Single Panel Expander Closure

The final closure panel is equipped with an expander mechanism in the same way as the more common expander panel. The single panel expander shall be center hung and capable of rotating 360° and, is equipped with an adjustable bottom seal (standard) or (optional) operable bottom seal and is used specifically with hinged pairs operation, and includes a flush pull handle. (Maximum panel height is 12'-2" [3710]).

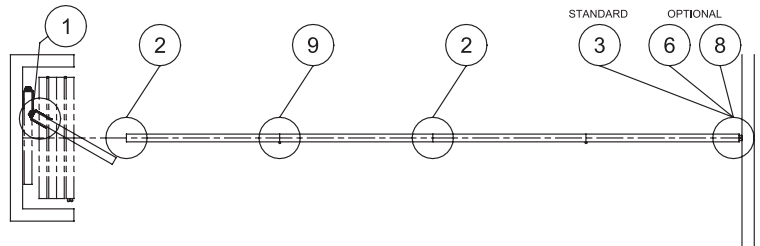

Optional Double Pocket Doors with Expander Closure

The pocket door is equipped with an expander mechanism in the same way as the more common expander panel. Rather than being located on a wall panel, the expander saddle is integrated into a pocket door panel. The saddle expander will be fully retracted with a pair of bulb seals compressed against the last panel exiting the stack. The pocket doors are provided with fixed bottom seals as a factory standard and includes a foot bolt and flush pull handle.

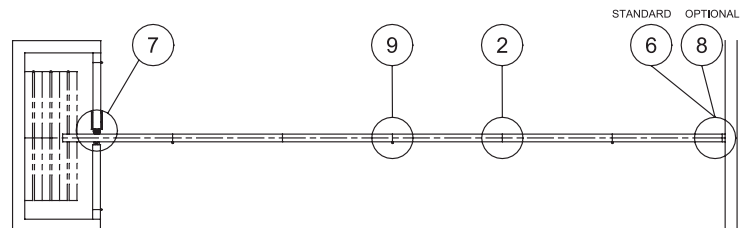

NOTE: Horizontal details for numbers 1 - 10 referenced above can be found on Pages 10 and 11.

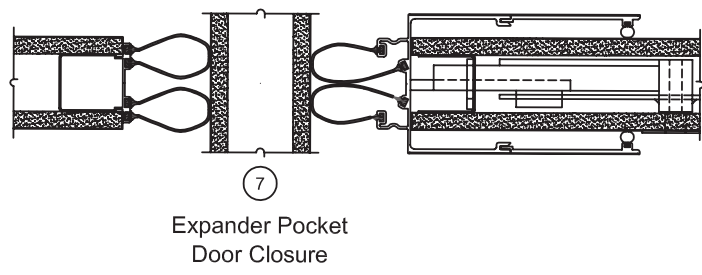
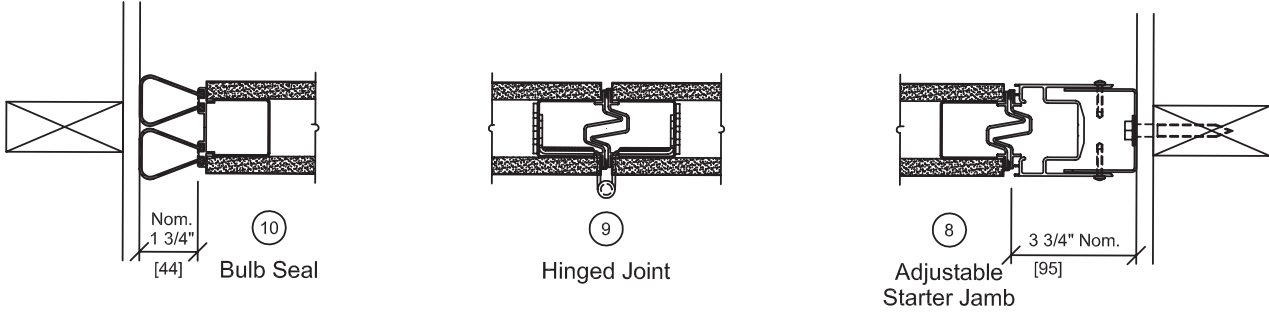
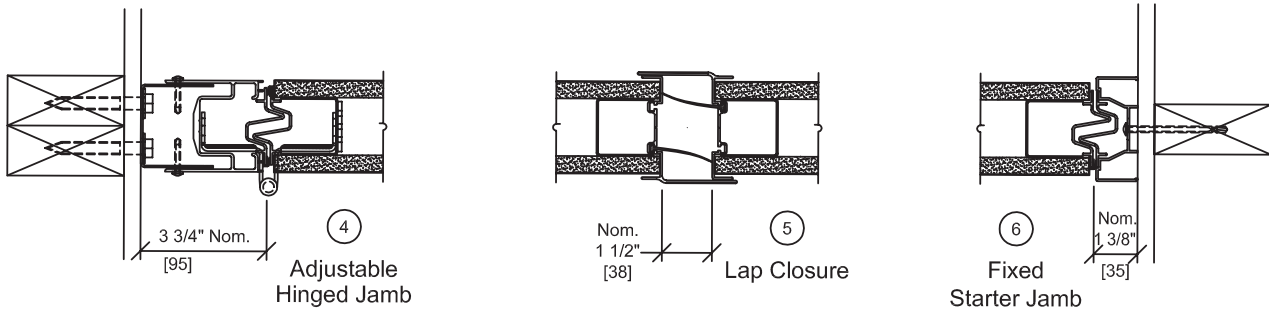
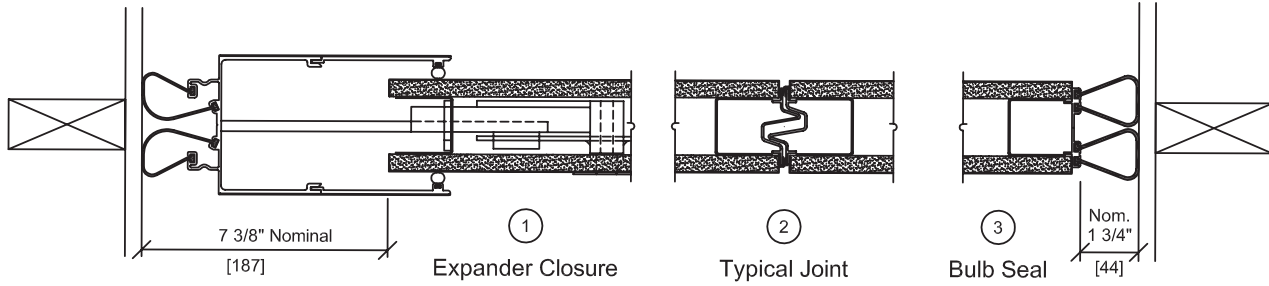

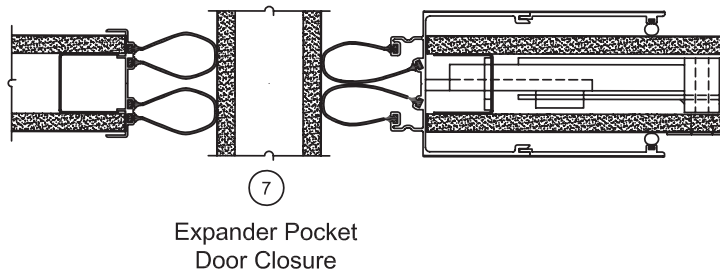
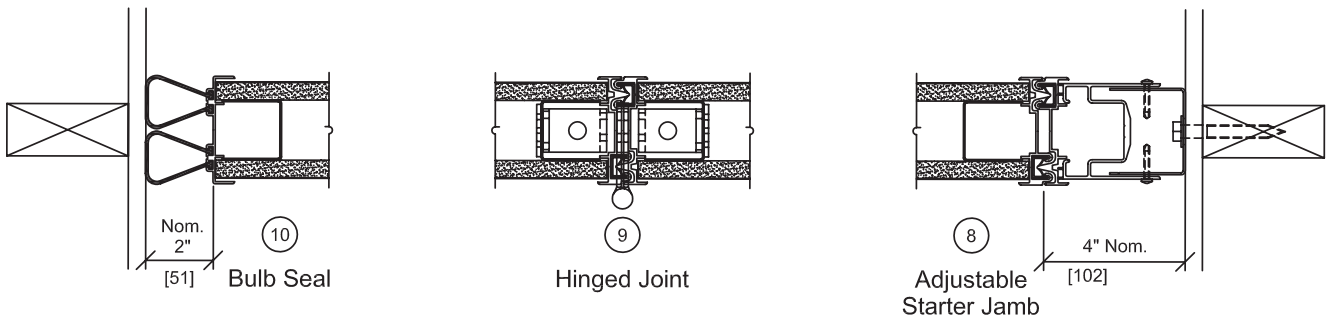
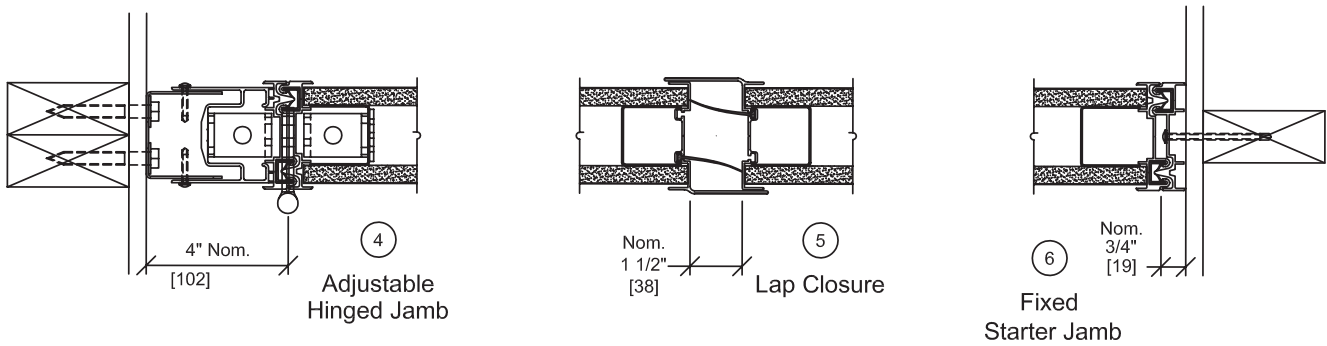
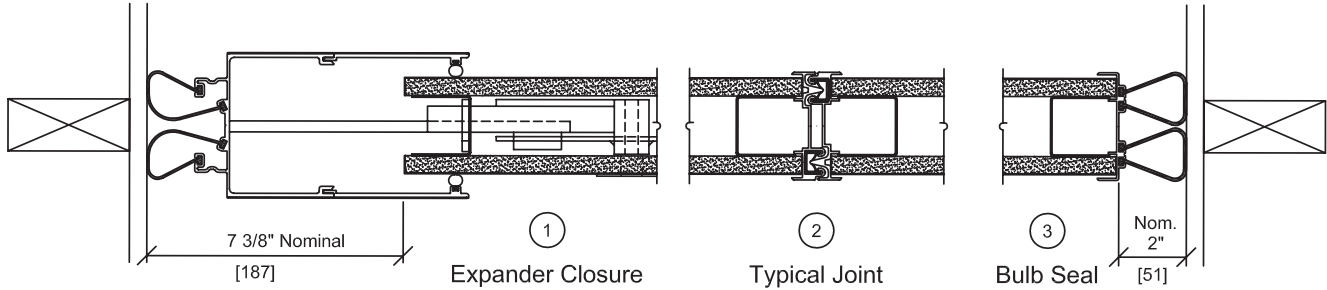

KWIK-WALL Company warrants each operable wall panel and its component parts to be free from defects in material and workmanship for a period of five (5) years from date of delivery to the original purchaser, when installed by an authorized KWIK-WALL distributor. KWIK-WALL also warrants the fixed top seals, track, carriers, and its component parts to be free from defects in material and workmanship for a period of ten (10) years. The Model 3050 electric wall because of its special track and carrier system will continue to carry the standard five (5) year warranty for all components. KWIK-WALL Company reserves the rights to have authorized personnel inspect any part alleged to be defective and to refuse any returned material unless the return was previously authorized by KWIK-WALL.

This warranty does not apply to any damage or deterioration caused by abuse or failure to provide reasonable and necessary maintenance. All field applied finishes, accessories or product modifications are specifically excluded under this warranty. KWIK-WALL's liability hereunder is limited to the replacement of any panel or component part found to be defective. Labor charges are the responsibility of the customer.

In order to keep the warranty valid, routine maintenance must be performed in accordance with manufacturer's specifications on the operable wall system. A maintenance log must be maintained indicating dates, type of service performed and the certified Kwik-Wall distributor who performed the service.

KWIK-WALL SHALL NOT BE LIABLE FOR ANY CONSEQUENTIAL OR INCIDENTAL DAMAGES. ALL OTHER WARRANTIES EXPRESSED OR IMPLIED INCLUDING ANY IMPLIED WARRANTY OF MERCHANTABILITY ARE HEREBY EXPRESSLY EXCLUDED.

Some states do not allow the exclusion or limitation of consequential or incidental damages, so the above limitation or exclusion may not apply to you. This warranty gives you specific legal rights, and you may have other rights, which vary from state to state.

Note:

Due to ongoing research and development, some variation may occur in product specifications and design. Please refer to your actual KWIK-WALL shop drawing(s) for exact product dimensions and specifications.

Distributed By:

